



BENOIT TURPIN & ALEXIS ALLARD



ANNE HEIDSIECK

# Welcome TO THE MOON



## RULEBOOK

GAME OVERVIEW.....	2
COMPONENTS.....	3
STANDARD RULES.....	4
ASTRA SOLO MODE.....	7
ADVENTURE #1 - THE LAUNCH.....	10
ADVENTURE #2 - THE JOURNEY.....	13
ADVENTURE #3 - THE COLONY.....	16
ADVENTURE #4 - THE MINE.....	19
ADVENTURE #5 - THE DOME.....	22
ADVENTURE #6 - THE VIRUS.....	25
ADVENTURE #7 - THE ESCAPE.....	29
ADVENTURE #8 - THE BATTLE.....	32

# GAME OVERVIEW



*"Citizens of Earth, we are facing a dire situation. Our planet is doomed. The fate of humanity is in your hands... It is no longer about preserving our way of life or our economy. Now, it is a struggle for our very existence. And our survival depends on our capacity to conquer the Moon. This conquest, this last hope of survival, we entrust it to you. You'll be in competition with each other in order to give us the best chances of success. You will write a decisive page of our History by saving us all.*

*Welcome to the Moon!"*

Excerpt from the address of Katalin Nelson Blue, the first president of the Human Alliance.

*Welcome to the Moon* is the last episode of the *Welcome to...* trilogy of games. After the residential housing estates of the 1950s, after the casinos of the 1960s, you will aim to conquer space...

*Welcome to the Moon* is an evolving and narrative flip & write game. It contains 8 different Adventures that form a complete story with an increasing difficulty level. You can play these 8 Adventures independently, or successively to play out your story.



## EVOLVING CAMPAIGN MODE

The **Campaign Book** will let you discover *Welcome to the Moon* by playing its 8 Adventures in order, from the 1st to the 8th. Moreover, during each campaign, you will influence the course of events thanks to **Campaign cards**, and therefore create a different story each time. *Welcome to the Moon* is an evolving game but stays absolutely replayable, because none of the components is destroyed from one game to another, nor permanently modified.

To play a campaign, first, you need to read the **standard rules**. Then take the **Campaign Book** that will guide you step by step. We suggest that you start with the **introduction campaign** in order to gradually discover the rules of each Adventure.

At the end of each Adventure you can save your progress. And you will receive stars depending on your result. The player with the most stars at the end of the campaign will be the winner.

## ADVENTURE MODE







You can also play each of the 8 Adventures separately. To play an Adventure, you must first read the standard rules. Then pick an Adventure and read the specific rules of this Adventure.

The player with the most points at the end of the Adventure is the winner.

# COMPONENTS

NOTE: All cards have an identification number that serves no purpose during the game.

## ◆ 63 Starship cards

Front: the Starship number / Back: the Action.  
 Number side: 2x "1/2/14/15 cards", 3x "3/13 cards", 4x "4/12 cards", 5x "5/11 cards", 6x "6/7/9/10 cards" and 7x "8 cards".  
 Action side: 14 robot  / energy  / plant  cards, 7 water  / astronaut  / planning  cards.

Identification numbers: 1 to 63.

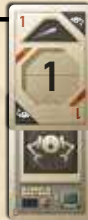

## ◆ 48 Mission cards

6 Mission cards for each of the 8 Adventures.  
 There are 3 different types of cards: mission A, B or C.  
 Front: mission initiated / Back: mission accomplished

Identification numbers: 64 to 111.



## ◆ 6 dry-erase markers

## ◆ 11 cards for the ASTRA Solo mode

Identification numbers: 112 to 122.

### 3 ASTRA Effect cards

### 4 ASTRA Opponent cards

Dry-erase on both sides.

### 4 cards ASTRA Adventure

Dry-erase on both sides.



## ◆ 1 dry-erase Captain card

For Adventure #8 and the Campaign mode.

Identification number: 123.



## ◆ 97 cards for the Campaign mode

**WARNING:** Please do not look at them unless you are invited to...

Identification numbers: 124 to 220.

## ◆ This rulebook for the Adventure mode and the Solo mode



## ◆ 1 Campaign book for the Campaign mode



## ◆ 24 double-sided dry-erase Adventure sheets

4 sheets per player with a different Adventure on each side: 8 Adventures numbered from 1 to 8.

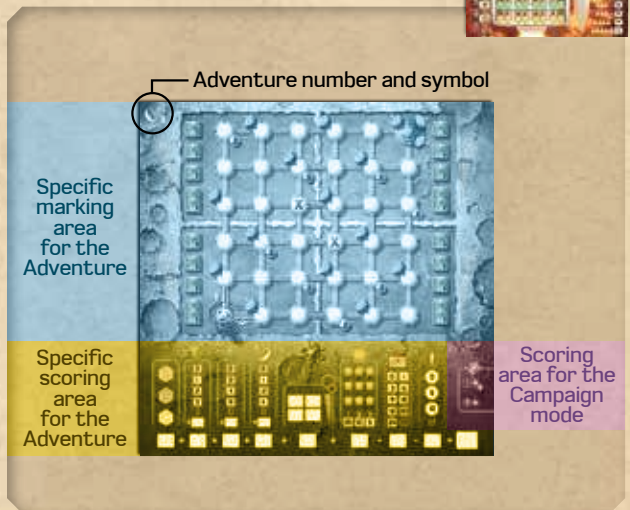

# STANDARD RULES

The 8 Adventures are all played with the same Starship cards (numbers/actions). However, the way you play will be different from one Adventure to the next...

The following standard rules are valid for all Adventures. And each Adventure gets its own specific set of rules that will be explained later on. We suggest that you do not read them all, but instead discover them gradually as the story progresses.

In case there is a specific rule for the Adventure that contradicts the standard rules, the specific rule for the Adventure takes priority.

## SET UP

- 1 Take **1 dry-erase marker** and the **Adventure sheet** on the side that was chosen for this game. The Adventure sheets are numbered on the top left corner. All the other sheets and markers are put back in the box.
- 2 Take the **Mission cards** that match the chosen Adventure. The Missions cards are numbered on the top right corner. Among these cards, select 3 of them: 1 Mission A card, 1 Mission B card, and 1 Mission C card. Place these 3 cards in the middle of the table, mission initiated face up. All the other Mission cards are put back in the box.
- 3 Shuffle the **Starship cards** and split them into 3 equal draw piles in the middle of the table, number face up.



## GAME TURN

A game is played in successive turns. Each turn is made up of the following 6 phases.

### 1 - FLIP 3 STARSHIP CARDS

At the beginning of each turn, the top card of each draw pile is flipped and placed in front of its pile, action face up.

This way, each turn, you get 3 new number/action combinations. Flipped cards are stacked in 3 discard piles.

When you flip the last card of each draw pile, shuffle separately the 3 discard piles in order to form 3 new draw piles of cards, number face up.



### 2 - PICK A NUMBER/ACTION COMBINATION

The players' turn is simultaneous: each player individually picks one of the three available combinations and applies the results on their sheet. Several players can therefore pick the same combination.

### 3 - WRITE DOWN A NUMBER (COMPULSORY)

You must write down the number of the combination you picked in an empty space of the marking area of your Adventure sheet. These spaces are grouped in different zones depending on the Adventure you are playing. In each zone, the numbers must be placed in ascending order from the lowest to the highest. A number can never appear twice in the same zone.



**Note:** In a zone, you can leave as many empty spaces as you wish between two numbered spaces, then fill them later on, as long as you keep respecting the ascending order. Likewise, you can skip some numbers (for instance: put an 8 just after a 6).

If you can write down at least one of the 3 available numbers, you must pick this combination. If you cannot write down any of the 3 numbers, then you must cross off 1 **System Error** box in the scoring area of your sheet, and you cannot perform any action this turn. You must cross off the System Error boxes from top to bottom.



### 4 - USE THE ACTION (OPTIONAL)

You can use the action of the combination that you picked, as long as you have filled in a space of your sheet with the number of the combination.

**Reminder:** An action is always optional!

### THE ACTIONS

You will always perform the same 6 actions, but in different ways depending on the Adventure you will be playing. Here are the general instructions for each action, then you will find important details for each of them in the specific rules for each Adventure.



**The Robot action** allows you to connect, build, cut or explore different parts depending on the Adventure you are playing.



**The Water and Plant actions** allow you to collect resources and earn points or bonuses, but only if you write the number associated with them in specific spaces of your Adventure sheet.



**The Energy action** allows you to improve other actions or their values.

**Note:** You can always write down a number associated with a Water/Plant action, outside of the intended spaces, and conversely, you can write down a number associated with another action in a space intended for a Water/Plant action. But in both cases, you cannot perform the Water/Plant action.



**The Astronaut action** allows you to modify the value of the number of the chosen combination, before you write it down, by adding or subtracting: -2, -1, 0, +1, or +2. This way you can get a 0 with a number 1 or 2. However you cannot go below 0. You can also get a number higher than 15 (16 or 17). Moreover, depending on the Adventure, this action will also give you additional bonuses. So it can be interesting to use the Astronaut action even if you do not modify the number, in order to get these bonuses.



**The Planning action** allows you to fill in an additional space on the same turn, besides the space in which you have written down the number of your combination. To do that, you can write down an X in an empty space of your choice. This way, you can have a series of numbers like this : 2-4-X-5-6. Moreover, depending on the Adventure, this action can also give you either penalties or additional bonuses.

Note: The spaces filled in with X are considered numbered spaces.

## 5 - INCIDENTS

Some effects or consequences that can be triggered during the different Adventures are resolved at this moment.

## 6 - ACCOMPLISH A MISSION (OPTIONAL)

The 3 Mission cards are objectives that have been given to you by the Human Alliance. Each Adventure has different missions that are explained in the specific rules to each Adventure. The first players to fulfill, in the same turn, the requirements of the mission can accomplish it. They write the highest value of the Mission card in the corresponding A, B or C space on their sheet.



Then the Mission card is flipped on the mission accomplished side.

From now on, those who accomplish the mission in a future turn will then get its lowest value.

You can only accomplish each of the 3 missions once during the game. When you have accomplished a mission, you keep the points you earned, even if you do not meet the requirements anymore later on.



## END OF THE GAME

The game ends at the end of a turn if one of the players has:

- ▶ accomplished **all three** **and** **Missions.**
- ▶ crossed off all the **System Error** boxes on their sheet.
- ▶ filled in **all the spaces** of the marking area on their sheet with numbers or X.

Add up the points of your accomplished missions and the points for each scoring field (Water, Plants...). Lose points for your System Errors: by subtracting the first visible value from your total or, for the first Adventure, by subtracting the sum of all your System Errors. The player with the most points is the winner of the Adventure. In case of a tie, the player with the least System Error boxes crossed off is the winner. In case of another tie, you share the victory.

In **Campaign mode**, you receive stars for each Adventure, depending on your achievements. Then you can move on to the next Adventure, by reading the next chapter in the **Campaign Book**.

General note: In all the cases of tie, the points for the first place are awarded to all first players. Then all the second players are awarded the points for the second place, and so on.

# ASTRA SOLO MODE

The private space agency ASTRA (Astral Space Technology & Robots by Alexis Inc.) is your main competitor in this space race. Its goal is to take over the most profitable resources and to proclaim its own law. This is unacceptable. We are counting on you!

All the standard rules and the specific rules for each Adventure apply normally, with the following changes. You will also have additional rules depending on the Adventure you play, in the corresponding sections.

## SET UP

- 1 Pick an **ASTRA Opponent Card**. The number next to their name shows the difficulty level (1 = easy). The bottom of the card shows the first part of the ASTRA scoring area.

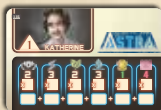

- 2 Take the **ASTRA Adventure card** corresponding to the Adventure you play. The bottom of this card shows the second part of the ASTRA scoring area.

The top of the card shows how to get Solo bonuses in order to penalize ASTRA.

The card also shows an ASTRA Effect that will allow ASTRA to penalize you with the ASTRA Effect cards. These effects are different from one Adventure to another, and you will find their description in the specific rules for each Adventure. But you don't need to know more about it now.

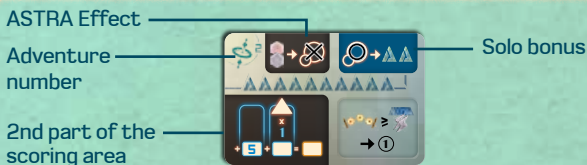

- 3 Place the **ASTRA Opponent card** and the **ASTRA Adventure card** on a line in order to create the ASTRA scoring area.



- 4 Shuffle the **Starship cards** and split them into 3 equal piles, with their action side face up. Shuffle all **three A, B and C ASTRA Effect cards** in one of the 3 piles. Then place the other 2 piles on top of it to form one draw pile of Starship cards, action face up.



## GAME TURN

- ▶ **Draw 3 cards:** On each turn, draw 3 Starship cards. If you draw one ASTRA Effect card, you must resolve it immediately (see further: ASTRA Effect cards). Then, place the ASTRA Effect card in your discard pile, and draw a new card, in order to have 3 Starship cards.
- ▶ **Use 2 cards:** Pick and use 2 of your 3 Starship cards, one for its number and one for its action. Then place these 2 cards in your discard pile.
- ▶ **Give 1 card to ASTRA:** At the end of the turn, give your third unused Starship card to ASTRA, by placing it aside, action face up. This way, you will form a pile of Starship cards that will earn points to ASTRA at the end of the game. You can check this pile of cards at any time. If you have enough space, sort the cards you give to ASTRA by action type. This will ease the calculations at the end of the game.

If you cannot write down any number of the 3 Starship cards, you have to cross off a **System Error** box (⚠). You still have to select one card to give to ASTRA and place the other two cards in your discard pile.

The first time that your draw pile of Starship cards is exhausted, shuffle only your discard pile with the 3 ASTRA Effect cards to form a new draw pile. The cards given to ASTRA do not come back into play. Then play on.

## ASTRA EFFECT CARDS

The ASTRA Effect cards have a different impact on the 1st time they are drawn and on the 2nd time.

**1** **On the 1st draw:** Each time you draw an **ASTRA Effect** card, either A, B or C, you must immediately apply the ASTRA Effect if possible. This effect is specified on the ASTRA Adventure card. It is different depending on the Adventure you play (see the specific rule of the corresponding Adventure).

**2** **On the 2nd draw:** After you have shuffled your discard pile and the 3 ASTRA Effect cards, whenever you draw again an ASTRA Effect card, either A, B or C, you must immediately apply the ASTRA Effect if possible.

Furthermore, you must immediately flip the corresponding A, B or C Mission card, on its Accomplished side. ASTRA does not earn points for that. But afterwards, when fulfilling this mission, you will not be able to get the maximum points.



## SOLO BONUS

The ASTRA Adventure card shows how to get Solo bonuses. You will get them through different ways depending on the Adventure you play (see the specific rule of the corresponding Adventure).

Each time you earn Solo bonuses, circle them on the ASTRA Adventure card. You can use them immediately, or later in the game.



A Solo bonus allows you to avoid giving a card to ASTRA. To do that, whenever you want, cross off an already circled Solo bonus. Then instead of giving ASTRA the third Starship card that you have not used, discard it permanently and put it back in the box. This way, ASTRA will not earn any point with this card at the end of the game.



## END OF THE GAME

- ▶ If you can not draw 3 Starship cards, because the draw pile is exhausted for the 2nd time, the game immediately ends.
- ▶ The game also ends at the end of the turn when **you** trigger one of the three end game conditions from the standard rules: you either have **accomplished the 3 missions**, or you have crossed off **all the System Error boxes** of your sheet, or you have filled in **all the spaces of the marking area** of your sheet.

To calculate the ASTRA score, for each type of action, write on the ASTRA Opponent card the number of Starship cards you gave them. Then, multiply these numbers with the value specified for each type of action.

Example: Katherine earns 2 points for each Robot card. So, if you have given her 7 Robot cards, she earns 14 points with the robots.

Tip: The actions with red values are those that earn ASTRA the most points. Avoid giving them too many. Conversely, the actions with green values earn them fewer points.

There is a fixed value on the ASTRA Adventure card that you must add to the ASTRA score. Furthermore, ASTRA earns points depending on the level of the ASTRA Opponent card: on the ASTRA Adventure card, write in the triangle the level number of the ASTRA Opponent you are playing against, then multiply this number by the specified value underneath.



Example: You play the Adventure #2 against Katherine (level 1): at the end of the game Katherine earns 5 points as well as  $1 \times 1 = 1$  extra point.



### IMPORTANT

To discover the game in the best conditions, we suggest that you stop reading the rules here.  
Open the Campaign Book to start the introduction campaign.  
This scenario will allow you to gradually discover the rules and the stories of each Adventure.



General note: The Adventure rules that follow only mention the modifications or add-ons to the standard rules. So you must apply the standard rules and refer to the particularities of the Adventures when necessary.

# ADVENTURE #1: THE LAUNCH

Asteroids have been hitting Earth for weeks and the situation is getting worse every day. You must leave Earth. For that, you must get a rocket ready as quickly as possible to go and colonize the Moon before it is too late. You must load equipment onto the different floors of the rocket according to its plan. This is a race against time and we are counting on you to launch your rocket before the others.



## GAME TURN

### 3 + 4 - WRITE DOWN A NUMBER USING THE ACTION (COMPULSORY)

There are 9 floors in the rocket. Each floor is an independent zone that must be numbered in ascending order from left to right.

In this Adventure, you won't perform any action. That means that none of the 6 actions has any effect. Each floor is tied to one of the action symbols (Astronaut, Water, Robot...). The actions only serve to show you where you can write down the number of the combination. So, each turn, you must write down a number on the floor tied to the action associated with that number.

The first floor, at the bottom of the rocket, is a Wild action floor, where any number can be placed, whatever the action of the combination, as long as the ascending order is respected.

Example: With a combination "6/Astronaut", you can write down the 6 on one of the two floors with astronauts or on the Wild action floor ①.

**System Error:** If you cannot write down any number during a turn, circle one of the System Error box (in no particular order) instead of playing ②.

Be careful, you will need to cross off each System Error previously circled with an Active Rocket effect, before being able to launch your rocket.

### THE QUARTER EFFECTS

Each floor of the rocket has one or more quarters separated with partition walls. As soon as you complete a quarter of a floor, having written down a number in each space of the quarter, apply its effects immediately. We suggest that you cross off the effects one by one before using them to avoid missing a sequence ③.

**X Building effect:** You can write an X in an empty space of your choice, which allows you to complete quarters faster ④.

**Rocket Activation effect:** There are Active and Inactive Rockets (see the symbols opposite). With the Activation effect, fill in the arrow of an Inactive Rocket in order to activate it, in any quarter that is not fully numbered ⑤.

**Active Rocket effect:** Each Active Rocket gives a number of rockets that you must cross off in the scoring area on the right. Start with the bottom line, then go up, line by line. As soon as you finish a line, cross off the scoring box at the end of the line. **Then**, you will be able to cross off your circled System Error boxes. Finally, if you still have some rockets to cross off, cross off the rockets next to the final scoring space ⑥.

**Sabotage effect:** During phase 5, announce a Sabotage. Your opponents must circle a System Error on their sheet, then cross off the same Sabotage symbol that you have just triggered. Your opponents will no longer be able to trigger it themselves. If several players trigger the same Sabotage of the same floor in the same turn, then this Sabotage does not impact those who have triggered it, and impacts the other players only once. If you trigger several Sabotages, they will be dealt with independently. Before being able to launch, you must cross off all the System Error circled with the Active Rocket effects ⑦.

### 5 - INCIDENTS: TRIGGER SABOTAGES

The Sabotage effects are announced and triggered at this moment of the turn.

### 6 - ACCOMPLISH A MISSION

In this Adventure, an accomplished mission does not earn you points at the end of the game, but gives you an **Active Rocket effect** that allows you to immediately cross off in your scoring area the number of rocket symbols specified on the card and/or System Error circled boxes. As soon as you accomplish a mission, you must cross off the corresponding mission space on your sheet ⑧.



Active Rocket



Inactive Rocket



Rocket Activation

## END OF THE GAME

The game can end either with **one of the 3 end conditions** from the standard rules, or **as soon as a rocket is launched**.

To launch your rocket and win the game, at the end of the turn, you must have crossed off all the rockets below the 150 scoring box, as well as all the System Error boxes circled on your sheet. The 8 rockets next to the final scoring space can be crossed off to win a tie (9): if several players launched a rocket during the same turn, the winner is the player who has crossed off the most of these rockets.

In case of a standard rules end condition, scores are tallied, and whoever has the highest score is the winner. Your score is equal to the lowest rocket score still visible, from which you must subtract 5 points for each circled System Error box that hasn't been crossed off.

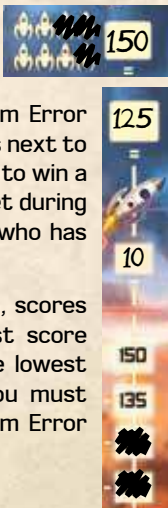

## THE MISSIONS



Number the 3 Astronaut & Water floors completely.



Number the 3 Robot & Planning floors completely.



Number the Energy floor completely.



Number the Plant and Wild floors completely.



Write down 10 X with the Building effects.



Have 5 System Error boxes circled and not crossed off.

## ASTRA SOLO MODE

Before starting the game, on the ASTRA Adventure card #1, cross off all the boxes with a blue number higher than the level of the ASTRA Opponent against whom you are playing.

Example: If you play against Katherine (level 1), you must cross off all the boxes numbered from 2 to 8.

You will not tally up ASTRA's score at the end of the game, because during the whole game you will use the scoring track on the ASTRA Adventure card. Each time you give a Starship card to ASTRA, immediately cross off the number of boxes corresponding to the action type, as specified on the ASTRA Opponent card. You must cross off the boxes from left to right, starting with the top row.

Example: If you play against Katherine, when you give her a Robot card, you must immediately cross off 2 boxes on the ASTRA scoring track.

As soon as you cross off its last box, ASTRA launches its rocket and wins the game with 150 points. Launch your rocket before ASTRA to win the game. If you launch your rocket during the same turn as ASTRA, it is a tie, unless you have crossed off one or more rockets next to the final scoring space. In this case, you win the game. If the game is over before either rocket is launched, compare your score with ASTRA's to figure out who is the winner. The ASTRA final score is the lowest visible score on its score track.

**SOLO BONUS:** Each time you trigger a Sabotage effect, circle 1 Solo bonus on the ASTRA Adventure card.

**ASTRA EFFECT:** As soon as you draw an ASTRA Effect card, either A, B or C, select one Sabotage effect still available in your marking area and cross it off immediately. From now on, this bonus is no longer available for you. In addition, circle 1 System Error immediately.

# ADVENTURE #2: THE JOURNEY

Your rocket was launched just in time. But the journey to the Moon will not be easy. You must set the course of your rocket, carry out trajectory corrections at the right time, plan the stirring of the water tanks, and prepare the plants on the space stations so that you can retrieve them with the robots. We count on you to optimize this journey so that you'll land on the Moon in the best possible conditions.

The board game board is a circular path connecting Earth and the Moon. It includes several resource management and action areas:

- Top Left:** A control panel with a dial set to 2, a grid of 8 lightning bolt icons, and 4 downward arrows.
- Top Right:** A circular path of hexagonal nodes around the Moon, with a central Moon icon. Nodes are numbered 1 through 12.
- Bottom Left:** A control panel with a dial set to 2, a grid of 8 lightning bolt icons, and 4 downward arrows.
- Bottom Right:** A control panel with a dial set to 2, a grid of 8 lightning bolt icons, and 4 downward arrows.
- Bottom Center:** A resource management area with a grid of 4 columns and 3 rows of hexagonal slots, a water tap icon, and a mathematical equation:  $\square + \square + \square + \square + \square - \square = \square$ .

The main path consists of hexagonal nodes connected by a dotted line. Key features include:

- Earth:** A central Earth icon with a rocket launching. Nodes around it are numbered 1 through 7.
- Moon:** A central Moon icon with a rocket landing. Nodes around it are numbered 1 through 12.
- Space Stations:** Four circular space station icons with green plants, each with a numbered circle (1, 2, 3, 4) and a lightning bolt icon.
- Resources:** Various icons including lightning bolts, water drops, and plants are scattered along the path.

## GAME TURN

### 3 - WRITE DOWN A NUMBER (COMPULSORY)

At the beginning of the game, the trajectory to the Moon is one long zone that you must number in ascending order from the Earth to the Moon. This trajectory is way too long to be numbered completely. As the game progresses, with the Energy action (see later on), you can split the trajectory into several smaller zones that you can number independently from each other (1).

**System Error:** For each of the first two System Error boxes that you cross off, you get one Energy in compensation: immediately circle an Energy symbol at the top of your sheet (2). If you have 2 circled Energies, you must immediately use them (see Energy action).

### 4 - USE THE ACTION (OPTIONAL)

 **Energy action:** The energy allows you to turn on the engines of your rocket, in order to create a boost to correct your trajectory. For that purpose, circle one Energy symbol at the top of your sheet (2). At the beginning of the game, you start with one energy already circled. Each time you have 2 circled energies, you must **immediately** cross them off, then divide a zone on your trajectory by drawing a line between 2 spaces of your choice, numbered or not. This line shows the end of one zone, and the beginning of another one. This way you will get shorter zones that you must number independently from one another (1).

 **Water Action:** It is important to stir the water tanks. If you have written down the number of your combination in a space with a water tank, then, with the Water action, you can circle that water tank (3).

Reminder: check the Water action note on page 5.

 **Robot action:** You must program the robots to retrieve the plants from the space stations. The stations are already connected to your trajectory by the robots, but you must activate them in order to retrieve

the plants and earn points. No matter where you have written down the number of your combination, with this action, you can circle a robot sent towards any station (4). The first players to circle all the robots of a station, during the same turn, can circle the highest multiplier (5). The other players must then cross off this multiplier and will be able to get only the lowest multiplier.



**Plant action:** You must organize the growing of the plants in microgravity in the space stations. These stations are connected to your trajectory by Robot symbols. With the Plant action, circle one plant in the station of your choice, as long as this station is connected to the zone where you have written down your number. At the beginning of the game, you can reach all stations from any space on your trajectory, because the 4 stations are connected to the one and only zone that makes up your trajectory. But gradually, through the use of the energies, you will split your trajectory in multiple separate zones. Thus, each station will be connected only to a specific zone, and a Plant action will only reach it if the number is written in this zone. **Note that you can circle the Plants of a station even though you have not circled all the robots for this station (6).**



**Astronaut action:** The Astronaut action allows you to modify the value of the number of the chosen combination, before you write it down (-2, -1, 0, +1, +2). Moreover, cross off 1 Astronaut symbol on the right side of your sheet. Whenever you have 2 crossed off Astronauts, circle a Wild Action symbol (7).



**Planning action:** The Planning action allows you to fill in a space with an X in addition to the number of your combination. Moreover, cross off 1 Planning symbol on the right side of your sheet. Whenever you have 2 crossed off Planning, circle a Wild Action symbol (8). Note that you cannot cross off a Planning symbol without writing down an X in an empty space.



**Wild action:** You can use a circled Wild Action symbol whenever you want (9). To use it, cross it off, then use any of the 6 possible actions **instead** of the one from your number/action combination.

## END OF THE GAME

At the end of the game, in addition to points earned for accomplished missions and penalty points lost for System Errors, tally up your points in each scoring area as follows:

### ► Plants:

For each space station, multiply the number of circled plants by the multiplier bonus that you have circled with the robots. Be careful, if you have not circled all the robots for a station, you will not score anything for it.



### ► Water tanks:

Add up the values of each circled water tank.

### ► Longest complete zone:

Score one point per numbered space for the longest complete zone (all numbered spaces) on your trajectory.



### ► The most zones complete:

Those who filled in the most zones on their course earn 20 points, the second ones earn 10 points, and the third ones earn 5 points. You do not earn any points if you do not have at least one complete zone.



## THE MISSIONS



Circle a multiplier bonus for 3 different space stations with the robots.



Circle all the plants for 2 space stations. All the robots do not have to be necessarily circled.



Using the energy, create on your trajectory 2 zones of 6 numbered spaces.



Using the energy, create on your trajectory 3 zones of numbered spaces: 1 zone of 6 spaces, 1 zone of 4 spaces and 1 zone of 2 spaces.



Circle 6 water tanks.



Circle 4 consecutive water tanks on your trajectory.

## ASTRA SOLO MODE

At the end of the game, on your course, if the number of complete zones is higher than or equal to the number of sets of two Energy cards given to ASTRA, then you are in the lead, and you earn 20 points for your complete zones. Otherwise, you are second and you earn only 10 points. You do not earn any points if you do not have at least one complete zone. ASTRA does not receive any additional points for that.

**SOLO BONUS:** Whenever you get the highest multiplier from a space station, circle 2 Solo bonuses on the ASTRA Adventure card.

**ASTRA EFFECT:** As soon as you draw an ASTRA Effect card, either A or B, choose a space station with the highest multiplier still available on your sheet and cross it off immediately. From now on, you will only be able to get the lowest multiplier of that space station. The ASTRA Effect C card does not trigger the ASTRA Effect, but when you draw it on the 2nd draw, you must nevertheless flip the mission C card.

# ADVENTURE #3: THE COLONY

Your rocket has landed on the Moon. You can now build the first lunar colony. You must construct buildings organized in rows and columns, as well as greenhouses for the plants, and water tanks. From the landing site, you also have to connect a network of parabolic antennas in order to observe the deep space. We count on you to maximize your colony to ensure its future development.

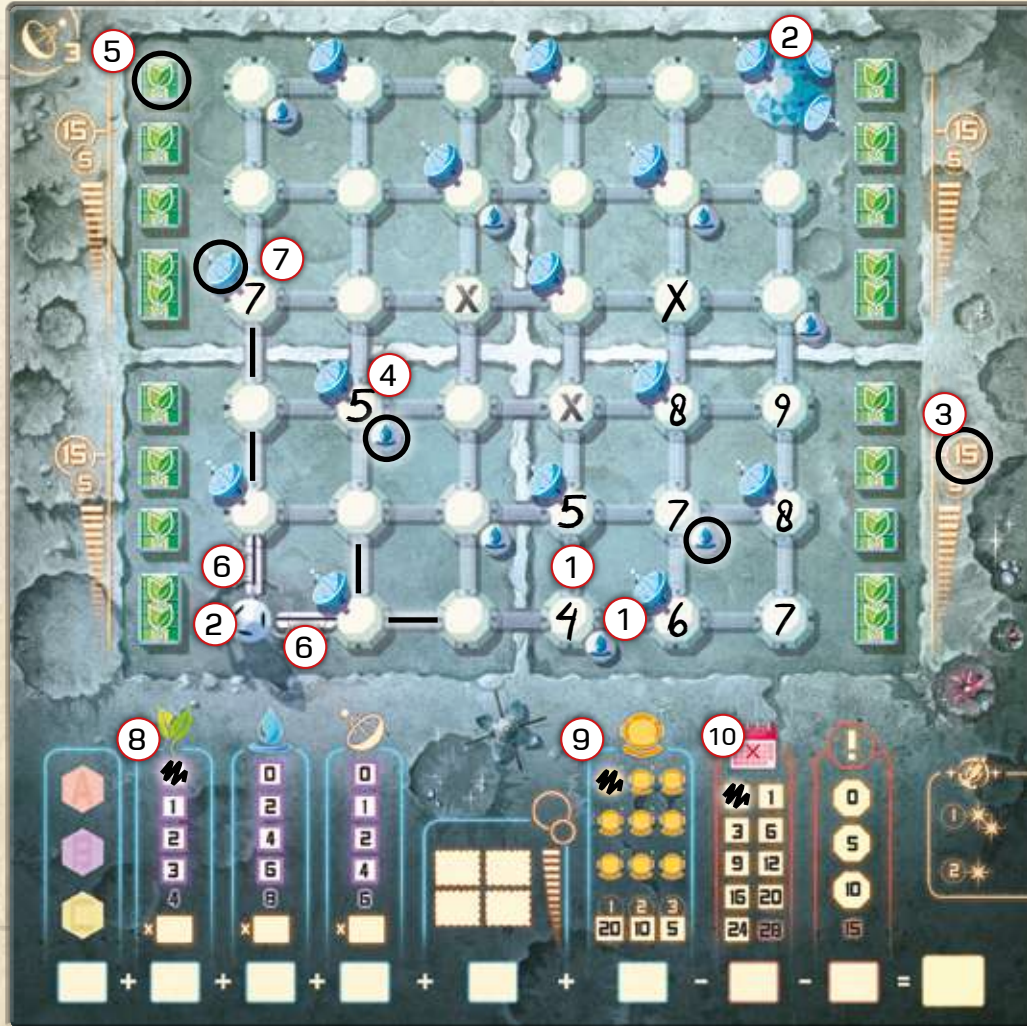



## END OF THE GAME

### 3 - WRITE DOWN A NUMBER (COMPULSORY)

In this Adventure, each building is a space to be numbered. Each row and each column of buildings forms a zone that you must number in ascending order. Each horizontal row of buildings must be numbered in ascending order from left to right. Each vertical column of buildings must be numbered in ascending order from bottom to top. When you write down a number on a building, you must make sure that this number is in the proper order in relation to the other numbers both in the same row and in the same column **1**.

The rocket at the bottom left side, and the observatory at the top right side are considered to be already numbered **2**. Moreover the two buildings marked with an X at the center of the colony are already constructed. So they are considered to be already numbered from the beginning of the game as well.

**The quarters:** The colony buildings are divided up into four quarters. The first players to write a number in all the buildings of one quarter, in the same turn, circle the highest bonus of 15 points **3**. The other players must then cross off this bonus, and will only be able to get the lowest bonus of 5 points.

### 4 - USE THE ACTION (OPTIONAL)

 **Water action:** If you write down the number of your combination in a building with a water tank, then with the Water action, you can circle that water tank **4**.

Reminder: check the Water action note on page 5.

 **Plant action:** You must build greenhouses in order to grow plants. For that purpose, circle one greenhouse in the same quarter where you have just written down the number of your combination **5**. You must circle

the greenhouses of a quarter from top to bottom. Each greenhouse will earn you 1 plant for the end of the game. The fourth greenhouse, which is larger, will earn you 2 plants.



**Robot action:** In order to dispatch the scientists and the equipment, you must create a network of pressurized tunnels connecting the buildings to one another. At the beginning of the game, you have already 2 tunnels built from the landing site of the rocket **6**. With the Robot action, draw a line on a tunnel to connect two buildings. These buildings do not necessarily have to be numbered. The line must start from a building already connected to the network. The network can branch out in multiple paths. As soon as a building with a parabolic antenna is numbered AND connected to your tunnel network, circle its antenna **7**. If you connect the observatory on the top right corner, immediately circle its 3 antennas.



**Energy action:** Using the energy, you can improve the greenhouses, the water tanks or the network of parabolic antennas. To do that, cross off one box in the scoring area of your choice: the plants, the water or the antennas **8**. You must first cross off the box with the lowest value, then the others from top to bottom.



**Astronaut action:** The Astronaut action allows you to modify the value of the number of the chosen combination, before you write it down (-2, -1, 0, +1, +2). Moreover cross off 1 Astronaut symbol in the scoring area of your sheets **9**.



**Planning action:** The Planning action allows you to fill in a space with an X in addition to the number of your combination. Moreover, you must immediately cross off the available box with the lowest value in the Planning scoring area at the bottom of your sheet **10**. The Planning action is powerful to quickly establish your colony, but it will cost you some points at the end of the game.

## END OF THE GAME

At the end of the game, in addition to points earned for accomplished missions and penalty points lost for System Errors, tally up your points in each scoring area as follows:

### ► Plants, Water tanks and parabolic antennas:

Tally the Plant symbols in your circled greenhouses, the circled Water tanks and the circled antennas. Write down these numbers in their corresponding scoring areas. For each of these three fields, multiply that number with the lowest visible value in the corresponding scoring area.



### ► Complete quarters:

Write down and add up the bonuses that you have earned for your completed quarters.



### ► Astronauts:

The players who have crossed off the most astronauts earn 20 points, the second ones 10 points, and the third ones 5 points. You do not earn any points if you have not crossed off any astronaut.

### ► Planning:

Subtract the lowest value still visible in the Planning scoring area.



Circle all the parabolic antennas in 2 quarters.



Circle enough greenhouses in order to have 10 plants.



Circle all the water tanks in 2 quarters.

## ASTRA SOLO MODE

At the end of the game, if your number of crossed off astronauts is higher than or equal to the number of Astronaut cards given to ASTRA, then you are in the lead and you earn 20 points. Otherwise, you are second and you earn only 10 points. You do not earn any points if you have not crossed off at least one astronaut. ASTRA does not receive any additional points for that.

**SOLO BONUS:** Whenever you get the highest bonus of 15 points by numbering all the buildings of a quarter, circle 2 Solo bonuses on the ASTRA Adventure card.

**ASTRA EFFECT:** As soon as you draw an ASTRA Effect card, either A or B, choose a quarter with the highest 15 points bonus still available on your sheet, and immediately cross it off. From now on, you will only be able to earn the 5 points bonus by numbering this quarter. The ASTRA Effect C card does not trigger the ASTRA Effect, but when you draw it on the 2nd draw, you must nevertheless flip the mission C card.

## THE MISSIONS



Number all the buildings in 3 vertical columns.



Number all the buildings in 3 horizontal rows.



Using the robots, connect the tunnel network to the observatory in the top right corner of your sheet.

# ADVENTURE #4: THE MINE

The colony is fully operational. It is now time to mine the underground resources of the Moon. We have discovered some precious minerals, as well as water and lunar plants. You must dig galleries in the lunar underground in order to extract these resources that will be processed on the surface in the factories of the colony. We count on you to take advantage of this wealth, because the colony needs to grow.



## GAME TURN

### 3 - WRITE DOWN A NUMBER (COMPULSORY)

The mine at the bottom of your sheet has 3 underground levels. Each horizontal level is an independent zone. It is made up of cavities: spaces that you must number in ascending order from left to right (1).

In the mine, there are 2 types of minerals that we commonly call “pearls” and “rubies”. When you write down a number in a space with a mineral, immediately circle it (2). Using the Water and Plant actions (see further), you can also circle plants and waters in the mine.

**Extract the resources:** By numbering the spaces, you will trigger the circled resources, which will allow you to supply your factories. The extraction of the resources is carried out during phase 5 (see further).

**The 6 main factories:** The 4 main factories on the left are processing the resources coming from the mine. To fill these factories, you must cross off the resources from top to bottom.



In each of these 4 factories, there is a resource linked to a filling bonus. The first players to circle the resource linked to a filling bonus, during the same turn, circle the bonus. The other players must immediately cross it off on their sheet and they will not be able to get it (3).

The 2 main factories on the right side are control centers for the astronauts and the planning (see Astronaut and Planning actions).



The main factories earn you points at the end of the game. You can upgrade their efficiency using the Energy and Robot actions (see further).

**The 5 secondary factories:** They are located above the main factories. You can activate them during the game to get instant bonuses (see Energy and Robot action).



### 4 - USE THE ACTION (OPTIONAL)



**Water and Plant action:** Both actions work in the same way. If you have written down the number of your combination in a cavity next to a Water or Plant, just above or below the cavity, then with the corresponding action, you can circle the resource (4).



**Astronaut action:** The Astronaut action allows you to modify the value of the number of the chosen combination, before you write it down (-2, -1, 0, +1, +2). Moreover, cross off 1 Astronaut symbol in the astronaut control center (5).



**Planning action:** The Planning action allows you to fill in a space with an X in addition to the number of your combination. Moreover, cross off 1 Planning symbol in the planning control center (6).



**Energy and Robot action:** Both actions work in the same way. Using an Energy or Robot action, you can cross off an Energy or Robot symbol in any factory (7).

► **Upgrading a main factory:** As soon as you have crossed off all the energies and robots of a main factory, cross off the scoring box located at the top of the factory. At the end of the game, the scoring box at the bottom of the factory will be the one taken into account (8).

Example: You have crossed off the energy and the 3 robots of the plant factory. At the end of the game, each crossed off plant in that factory will earn you 4 points instead of 2.

- ▶ **Activate a secondary factory:** As soon as you have crossed off all the energies and all the robots of a secondary factory, you activate bonuses that you must immediately use. In order to use them, cross off the bonuses, then circle or cross off the corresponding symbols in the factories (9). The 4 secondary factories on the left give you extra resources to circle in the main factories. The secondary factory on the right gives you 3 robots that you can cross off in one or several factories, either main or secondary.

- ▶ **Main Planning factory:** Multiply the total number of crossed off planning by the active value of the factory. Each crossed off planning usually makes you lose 3 points, but if you have upgraded the factory, then you will not lose any point.

## 5 - INCIDENTS: EXTRACTING THE RESOURCES

If you have numbered the 3 spaces of a column, then you must extract the resources of this column. Cross off the circled resources in this column (10). Then for each of these resources, circle a resource in the appropriate main factory (11). Then circle the extraction pump just above the column (12).







## END OF THE GAME

At the end of the game, in addition to points earned for accomplished missions and penalty points lost for System Errors, tally up your points in each scoring area as follows:

- ▶ **Main resource factories:** In each main resource factory, write down the total number of circled resources. Multiply that number by the active value of the factory, the one on top of the factory if you have not upgraded it or the one at the bottom if you have upgraded it. Add the filling bonus if you have obtained it.
- ▶ **Main Astronaut factory:** Multiply the total number of crossed off astronauts by the active value of the factory. The astronauts do not usually earn points, but if you have upgraded the factory, then each crossed off astronaut earns you 3 points.



## THE MISSIONS

-  In the mine, complete 5 extraction columns.
-  In the mine, complete 4 adjacent extraction columns.
-  Activate the 5 secondary factories located on the top of your sheet.
-  Upgrade or activate a total of 6 factories, either main or secondary.
-  Circle 8 plants in the mine, whether they are extracted or not.
-  Circle 5 waters in the mine, whether they are extracted or not.

## ASTRA SOLO MODE

**SOLO BONUS:** Whenever you earn a filling bonus of a main factory, circle 2 Solo bonus on the ASTRA Adventure card.

**ASTRA EFFECT:** As soon as you draw an ASTRA Effect, either A or B, choose a filling bonus of a main factory still available on your sheet and immediately cross it off. From now on, this bonus is no longer available for you. The ASTRA Effect C card does not trigger the ASTRA Effect, but when you draw it on the 2nd draw, you must nevertheless flip the mission C card.

# ADVENTURE #5: THE DOME

Thanks to your efforts, the colony is growing strong. You must now build the capital city of the Moon, with skyscrapers whose foundations plunge deeply under the lunar surface and a research tower fully dedicated to the lunar plants and water supply, all under a huge dome protecting everyone from the cosmic radiation. We count on you to build a city that will be a beacon of light for the whole universe.

The board features a central dome structure with various levels and components. A compass rose is in the top left, and a resource display is in the top right. The board is annotated with numbered callouts (1-8) pointing to specific elements:

- 1: Points to a resource panel on the left.
- 2: Points to a resource panel at the bottom center.
- 3: Points to a resource panel at the bottom right.
- 4: Points to a resource panel at the bottom right.
- 5: Points to a resource panel on the left.
- 6: Points to a resource panel on the right.
- 7: Points to a resource panel on the left.
- 8: Points to a resource panel at the bottom left.

At the bottom, there are several resource management panels, including a star resource panel, a water resource panel, a gold resource panel, and a health/energy panel. A mathematical equation is shown at the very bottom: [ ] + [ ] + [ ] + [ ] + [ ] - [ ] - [ ] = [ ].

## GAME TURN

### 3 - WRITE DOWN A NUMBER (COMPULSORY)

Each skyscraper is an independent zone made up of different levels: spaces that you must number in ascending order from bottom to top.

The first number that you write down in each skyscraper has to be placed in one of the 2 starting levels: the first level above the lunar surface or the first level below the surface. Afterwards you have to place a number in a level adjacent to an already numbered space, directly above or below it **1**.

The first players to reach the highest or lowest level of a skyscraper can circle the highest bonus of this level. The other players must immediately cross off this highest bonus on their sheet and can now only earn the lowest bonus for this level **2**.

### 4 - USE THE ACTION (OPTIONAL)



**Water and Plant action:** Both actions work in the same way. Some skyscraper levels are connected to the same levels of the Water & Plant research tower. With a Water or Plant action you can circle a Water or Plant symbol in the level of the tower connected to the skyscraper level where you have just written the number of your combination **3**.





**Astronaut action:** The Astronaut action allows you to modify the value of the number of the chosen combination, before you write it down [-2, -1, 0, +1, +2]. Moreover, cross off 1 Astronaut symbol in the scoring area at the bottom of your sheet **4**.



**Robot action:** This action allows you to build a section of the dome. To do that, draw one section of the dome according to the following rules.

► You can build only one of the 2 sections at the surface level or one section adjacent to an already built section **5**.

► Moreover, each section has a requirement. A section with 1 circle at each end  is an odd section type. A section with 2 circles at each end  is an even section type. If the number of your combination that you have just written down is even, you can only build an even section type. Likewise, with an odd number, you can only build an odd section type.

Example: with an “8 / Robot” combination, you can build the even section type that is located at the base of the dome on the right side **6**, or the first half of the even section on the left side, that has been cut up in half because of a Planning action **7**.



**Planning action:** The Planning action speeds up the construction of the skyscrapers, but slows down the construction of the dome. The Planning action allows you to fill in a level with an X in addition to the number of your combination: either one of the two starting levels of a skyscraper, or a level adjacent to an already numbered level.

In addition to that, with a line, you must cut in half one unbuilt section of the dome of your choice **7**. This way, you end up with 2 sections to build instead of one. Both new sections keep the odd/even type of the original section. One section can only be cut up in half once. If there is no more unbuilt section to cut up in half, then you can use the Planning action without having to be subjected to this penalty.



**Energy action:** With this action you can upgrade one of these 4 fields: the result of your **accomplished missions**, the **plant & water** research tower, the efficiency of your **astronauts**, and of your **dome**.

For that purpose, cross off one scoring box in your scoring area of your choice at the bottom of your sheet. You must cross off the boxes from top to bottom. The field of the plant & water tower has a triple scoring area. With one Energy action you can cross off 3 boxes at the same level. For example the 3 “2/5/9” boxes **8**. The missions and the astronauts follow the same logic with a double scoring area: cross off 2 boxes at the same level.

## 6 - ACCOMPLISH A MISSION (OPTIONAL)

In this Adventure, the missions earn you points that you can upgrade with the Energy action. The first players to accomplish a mission circle the ☆ symbol on the corresponding scoring space, either A, B or C. The other players can then only circle the ☆ symbol.

### END OF THE GAME

At the end of the game, in addition to penalty points lost for System Errors, tally up your points in each scoring area as follows:

► **Missions:** For each accomplished mission, depending on whether you have circled the ☆ or ☆ symbol, write down the lowest visible value of the corresponding scoring area.

► **Plants and Waters:** In the plant & water research tower, you will have levels with 1, 2 or 3 circled symbols (Plant or Water). In the 1st scoring column, write down the number of levels with only one circled symbol. In the 2nd scoring column, write down the number of levels with two circled symbols. In the 3rd scoring column, write down the number of levels with three circled symbols. In each column, multiply the number of levels you just wrote with the lowest visible value.

1st	2nd	3rd
2	6	10
3	7	12
3	8	15
4	10	18
2	5	1
4 + 30 + 10		

► **Skyscrapers:** Write down and add up the bonuses earned with the highest and lowest levels of the skyscrapers.

► **Astronauts:** Those who have crossed off the most astronauts earn the lowest visible value in the 1st scoring column, the others earn the lowest value of the 2nd scoring column. You do not earn or lose any points if you have not crossed off at least one Astronaut.

► **Dome:** You lose points if your dome is not finished. Write down the number of unbuilt sections of the dome and multiply this number with the highest visible value. Subtract those points to your score.

### THE MISSIONS



Number all the levels of one skyscraper.



Number the last level at the top of 2 skyscrapers.



In the plant & water tower, circle at least 2 symbols (2 plants or 1 plant + 1 water) in 3 levels.



In the plant & water tower, circle all 3 symbols (the 2 plants + the water) in 2 levels.



Build all sections of the dome.



Write down an X in 4 levels with Planning actions.

### ASTRA SOLO MODE

At the end of the game, if the number of your crossed off astronauts is higher than or equal to the number of astronaut cards given to ASTRA, then you are in the lead. Otherwise you are second and you earn the corresponding points. You do not earn any points if you have not crossed off at least one Astronaut. ASTRA does not earn any additional points for that.

**SOLO BONUS:** Whenever you get the highest bonus at the top or at the bottom of a skyscraper, circle one Solo bonus on the ASTRA Adventure card.

**ASTRA EFFECT:** As soon as you draw an ASTRA Effect card, either A, B or C, choose one highest bonus on top or at the bottom of a skyscraper that is still available on your sheet and immediately cross it off. From now on, you will only be able to earn the lowest bonus there.



# ADVENTURE #6: THE VIRUS

We do not really know how it happened... Maybe it was the water... Or the experiments grafting the earthly plants grown in microgravity with the lunar extraterrestrial plants... Whatever it was, several viruses have appeared. You are in charge of a housing unit. Quarantine the quarters if necessary to slow down the epidemic and evacuate as many people as possible. We count on you to carry on the scientific experiments despite all that. Even though it might be a risk for the population...

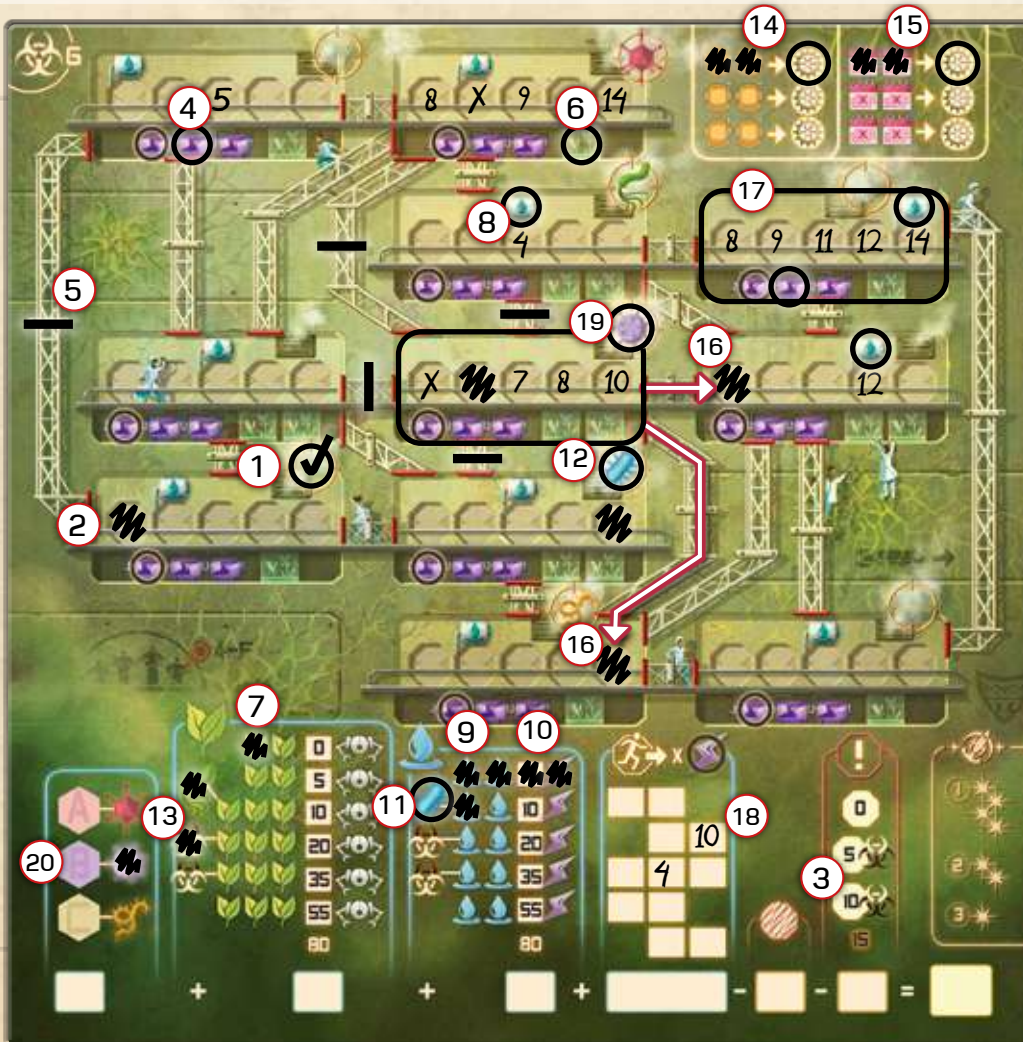

## SET UP

Before starting the game, select a quarter with an empty virus target . Draw a virus in this target and circle it to signal that this virus is active **(1)**. Each player can choose a different quarter for that virus. This is the “grey virus” and it immediately spreads. A housing space of that quarter is infected: cross off one housing space of your choice in that quarter **(2)**.

## GAME TURN

### 3 - WRITE DOWN A NUMBER (COMPULSORY)

You are in charge of a housing unit composed of 5 floors. Each floor is an independent zone with housing spaces that you must number in ascending order from left to right. Each floor is divided in 2 or 3 quarters of 5 housing spaces and these quarters are connected to one another by walkways. Some housing spaces will be infected/crossed off during the game, they will not matter for the ascending order of your numbers.

**System Error:** When you cross off the 2nd and 3rd System Error box, you trigger a **propagation**  of all active viruses, only on your sheet, during Phase 5 (see further: 5 - Incidents: Propagation of the Active Viruses) **(3)**.

### 4 - USE THE ACTION (OPTIONAL)

 **Energy action:** Circle one energy in the quarter where you have written down the number of your combination. Note that at the start of the game, there is already one circled energy in each quarter **(4)**.

 **Action Robot:** With this action, you can quarantine quarters to slow down the propagation of the viruses. Close one walkway of your choice, wherever on your sheet, with a line that will close the walkway **(5)**. This way, the quarters that were connected with this walkway are no longer connected. This will prevent the propagation of the viruses from one quarter to another. Closing a walkway that connects two quarters of the same floor

does not divide the zone and you must still number the whole floor in ascending order.



### Plante and Water action:

 **Plant:** Circle a plant **in the quarter** where you have written down the number of your number/plant combination **(6)**. Then cross off a Plant symbol in the scoring area **(7)**.

 **Water:** Circle the water tank if you have written down the number of your number/water combination in a housing space with a water tank **(8)**. Then cross off a Water symbol in the scoring area **(9)**.

In the scoring area, you must cross off the Plant and Water symbols from left to right, and from top to bottom starting from the top line.

Whenever you cross off the last symbol of a line of the scoring area, cross off the scoring box at the end of this line, as well as the Robot or Energy symbol that you must immediately use **(10)**. With the Robot, close a walkway. With the Energy, circle one energy in any quarter of your choice, except in a complete quarter; in other words, a quarter with all its housing spaces numbered or crossed off.

Whenever you cross off a symbol (Plant or Water) with a **virus activation symbol** ( or ) **(11)**, everyone must immediately activate it on their sheet by circling the corresponding virus target **(12)**. Everyone must also cross off the same activation symbol on their sheet, because each virus can only be activated once. Whenever a virus is activated, a propagation of all active viruses must be triggered for every player during phase 5 (see further: 5 - Incidents: Propagation of the Active Viruses).

Whenever you circle a symbol (Plant or Water) with a **Propagation symbol** , everyone must cross off this symbol on their sheet, because it can only be activated once **(13)**. A propagation of all active viruses must be triggered only for your opponents during phase 5 (see further: 5 - Incidents: Propagation of the Active Viruses). If several players activate the same Propagation symbol during the same turn, then this propagation does not impact those who have activated it, and impacts the other players only once.



**Astronaut action:** The Astronaut action allows you to modify the value of the number of the chosen combination, before you write it down (-2, -1, 0, +1, +2). Moreover, cross off 1 Astronaut symbol at the top of your sheet. Whenever you have 2 crossed off astronauts, circle a Wild Action symbol (14).





**Planning action:** The Planning action allows you to fill in a housing space with an X in addition to the number of your combination. Moreover, cross off 1 Planning symbol at the top of your sheet. Whenever you have 2 crossed off planning, circle a Wild Action symbol (15). Note that you cannot circle a Planning symbol without writing down an X in a housing space.



**Wild action:** You can use a circled Wild Action symbol whenever you want. To use it, cross it off, then use any of the 6 possible actions instead of the one from your number/action combination.

## 5 - INCIDENTS: PROPAGATION OF THE ACTIVE VIRUSES AND EVACUATION OF THE QUARTERS

► **Number and type of Propagation:** First of all, you must determine the number and type of propagation of the active viruses that you must trigger.

- **The infections** : For each virus that has been activated during the turn, every player must trigger a propagation of all active viruses. Therefore if 2 viruses have been activated during this turn, you must trigger a 1st propagation for all active viruses, then carry on with a 2nd propagation.
- **Water & Plant Propagation** : If a Propagation symbol has been triggered with a Plant or Water action, a propagation is triggered for all the players but those who have triggered it.
- **System Error Propagation** : If you have crossed off the 2nd or 3rd System Error box, you must trigger a propagation only on your sheet.

► **Trigger one propagation:** On your sheet, each active virus spreads, one by one, in the following order: from left to right, starting with the top floor; then going down floor by floor. A virus spreads by infecting a housing space in the quarter where it is active. Cross off one empty housing space of your choice in this quarter.

If the quarter is complete, with all its housing spaces numbered or crossed off, then the virus spreads to all the neighboring quarters directly connected to that quarter by a walkway. You must then cross off one housing space of your choice in each of these quarters. However the virus does not spread in a neighboring quarter if the walkway is closed. Likewise, the virus does not spread into a complete neighboring quarter and does not spread further on (16).

► **Evacuation of the complete quarters:** A quarter is complete when all its housing spaces are numbered or infected/crossed off. Then you must immediately score the points of this quarter. For that, multiply the number of numbered housing spaces by the number of circled energies in this quarter (17).

Write down this score in the corresponding space in the scoring area at the bottom of your sheet (18). You do not earn any points with the infected/crossed off housing spaces. Finally, circle this evacuated quarter. A quarter can only be evacuated and scored once.

## 6 - ACCOMPLISH A MISSION (OPTIONAL)

Whenever a mission is accomplished for the first time in the game, each player must activate the virus (red, purple or yellow) shown on the mission, by circling on their sheet the corresponding virus targets (19). Each player must also cross off the activation symbol of this virus in the scoring mission area, because each virus can only be activated once (20). Whenever a virus is activated, a propagation of all active viruses must be triggered for everyone. For that purpose, carry out the previous phase 5 again.

## END OF THE GAME

The 3 end game conditions from the standard rules apply. Note that the game will end if all your housing spaces are filled with a number or an X or crossed off due to an infection.

At the end of the game, in addition to points earned for accomplished missions and penalty points lost for System Errors, tally up your points in each scoring area as follows:

### ► Plants and water:

Score the points of the lowest visible scoring box.

### ► Evacuated quarters:

Evacuate all the remaining incomplete quarters and score their points on your sheet (multiply the number of numbered housing spaces by the number of circled energies). Then add up the points of all your quarters.

### ► Infected housing spaces:

You lose 1 point for each infected/crossed off housing space.

## THE MISSIONS



Evacuate 2 quarters. These quarters can be partially or even totally infected.



Evacuate all the quarters of one floor. These quarters can be partially or even totally infected.



Quarantine 3 quarters by closing all the walkways giving access to them. Each quarter must be independently quarantined from one another.



Quarantine the quarter with the green virus and the quarter with the blue virus, by closing all the walkways giving access to them.



Circle all the energies on 2 floors.



Circle all the plants and all the water tanks on 2 floors.

## MODE SOLO ASTRA

**SOLO BONUS:** Whenever you activate a virus yourself (with a mission or a Plant/Water action), or you trigger a Propagation symbol (with a Plant/Water action), circle 1 Solo bonus on the ASTRA Adventure card.

**ASTRA EFFECT:** The ASTRA Effect is different on the 1st and the 2nd draw of the ASTRA Effect cards.

**1 On the 1st draw:** Whenever you draw an ASTRA Effect card, either A, B or C, ASTRA **immediately** activates the green or blue virus, or triggers a propagation. In the scoring area, choose a virus activation symbol still available between green and blue, cross it off and activate the corresponding virus. If both green and blue viruses are already activated, select instead a Propagation symbol still available and cross it off. You must immediately (and not on phase 5) trigger a propagation of all active viruses.

**2 On the 2nd draw:** Whenever you draw an ASTRA Effect card, either A, B or C, **immediately** activate the virus shown on the corresponding Mission card, either A, B or C, and immediately (and not on phase 5) trigger a propagation of all active viruses. Then flip over the Mission card on its accomplished mission side.

# ADVENTURE #7: THE ESCAPE

The evacuation was carried out successfully. Luckily we had planned to leave anyway. But we must rush this exit and the new starships are not ready yet. Moreover, due to the emergency, they have been stacked horizontally above the domes, making most of them inaccessible. You must fix this. We count on you to help us escape this cursed Moon, through a vortex in the space-time continuum, and go on to conquer the universe.

The puzzle interface includes the following elements:

- Spacecraft Grid:** A grid of 13 spacecraft, numbered 1 through 13. Some numbers are circled in red (1, 2, 3, 4, 5, 6, 7, 8, 9) and some in black (7, 13). The spacecraft are arranged in a grid with some numbers circled in red and some in black.
- Legend:** A legend on the right shows a sequence of icons: a red circle with '9', a black circle with '4', a yellow circle with '4', and a yellow circle with '3'.
- Calendar:** A calendar showing the numbers 1 through 28.
- Calculator:** A calculator with a grid of numbers from 1 to 28.
- Icons:** Various icons including a rocket, a moon, and a star.
- Equation Bar:** A bar at the bottom with a plus sign, a minus sign, and an equals sign, followed by empty boxes for numbers.

## GAME TURN

### 3 - WRITE DOWN A NUMBER (COMPULSORY)

The starships are stacked horizontally, and each starship is an independent zone that must be numbered in ascending order from left to right. Each starship has 2 or 3 modules with several spaces each, as well as one greenhouse for the plants.

The modules, the greenhouses and the starships are connected to each other by airlocks . The problem is that these airlocks are not activated. You can only number a module or a greenhouse after having activated an airlock that gives access to it.

At the beginning of the game, you can only access the two modules of the lowest starship **1**. You can write down numbers only in the spaces of these two modules.

**The Robot bonus:** When you write down a number in a space with a Robot symbol **2**, you get a Robot bonus that you must immediately use by activating an airlock (see further: Robot action). This Robot bonus does not replace the action of your combination.

**The greenhouses x2 bonus:** The first players to write down a number in a greenhouse can circle the x2 bonus of this greenhouse **3**. The other players must immediately cross off the x2 bonus of this greenhouse on their sheet and will not be able to get it.

**System Error:** If you have to cross off a System Error box, the two first give you a compensation and allow you to immediately activate an airlock (see further: Robot action).

### 4 - USE THE ACTION (OPTIONAL)

 **Robot action:** With this action, you can activate an airlock. For that purpose, draw a line on an airlock between two modules or between a module and a greenhouse **4**. You can activate an airlock only if it is connected to a module or a greenhouse already connected.

That way you will access new modules, greenhouses and starships so that you can number them. Do not forget that each starship is a zone that must be numbered in ascending order. The airlocks, activated or not, do not change the numbering constraint of these zones.



**Water action:** If you have written down the number of your combination in a space with a water tank, then you can circle that water tank **5**.



**Plant action:** You can circle a plant in a greenhouse in the same starship in which you just have written down the number of your combination **6**. At the beginning of the game, some plants are already circled. You can circle a plant in a greenhouse even though it is not yet connected with an airlock.



**Energy action:** Fire the reactors. With this action, you can circle a reactor at the end of the same starship in which you just have written down the number of your combination **7**. At the beginning of the game, some reactors are already circled.



**Planning action:** The Planning action allows you to fill in an accessible space with an X, in addition to the number of your combination. Moreover, you must immediately cross off the box with the lowest value available in the Planning scoring area, at the bottom of your sheet **8**.



**Astronaut action:** The Astronaut action allows you to modify the value of the number of the chosen combination, before you write it down, [-2, -1, 0, +1, or +2]. Moreover, cross off 1 Astronaut symbol on the right side of your sheet. Whenever you have 2 crossed off Astronaut symbols, circle a Wild Action symbol **9**.



**Wild action:** You can use a circled Wild Action symbol whenever you want. To use it, cross it off, then use any of the 6 possible actions instead of the one from your number/action combination.

## END OF THE GAME

At the end of the game, in addition to points earned for accomplished missions and penalty points lost for System Errors, tally up your points in each scoring area as follows:

### ► The greenhouses:

Write down the score of each numbered greenhouse in the corresponding starship scoring space. A greenhouse earns you 2 points with 1 circled plant, 4 points with 2 circled plants, 7 points with 3 circled plants. If you have circled its x2 bonus, the value of the greenhouse is doubled. You do not earn any points for a greenhouse without a number or without any circled plant.

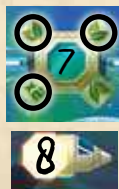

### ► The modules:

For each starship, write down the cumulative value of the modules that form it. For each starship, a fully numbered module earns you 2 points with 1 circled reactor, 4 points with 2 circled reactors, 7 points with 3 circled reactors. If you have circled its water tank, the value of the module is doubled. You do not earn any points for a module that is not fully numbered.

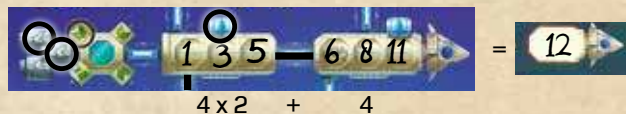

### ► Plannings:

Subtract the lowest visible value in the planning scoring area.

## THE MISSIONS



Number 3 greenhouses with their 3 circled plants.



Number the greenhouse of the highest starship with its 3 circled plants.

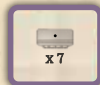

Number 7 modules completely.

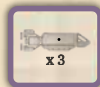

Number 3 starships completely.

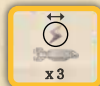

Circle all reactors of 3 starships.

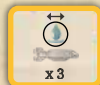

Circle all water tanks of 3 starships.

## ASTRA SOLO MODE

**SOLO BONUS:** Whenever you get a x2 bonus, circle 1 Solo bonus on the ASTRA Adventure card.

**ASTRA EFFECT:** As soon as you draw an ASTRA Effect card, either A, B or C, choose a greenhouse X2 bonus still available on your sheet, and immediately cross it off. From now on, this bonus is no longer available for you.

# ADVENTURE #8: THE BATTLE

Only two systems with inhabitable planets have been found: the twin systems of Neo Solaris 1 and 2. Therefore their colonisation has begun, but the resources on those planets are too scarce for the entire population. The battle is unavoidable... We count on you to occupy the ground and take control of as many planets and resources as possible. The competition with your nearest opponents will be fierce...

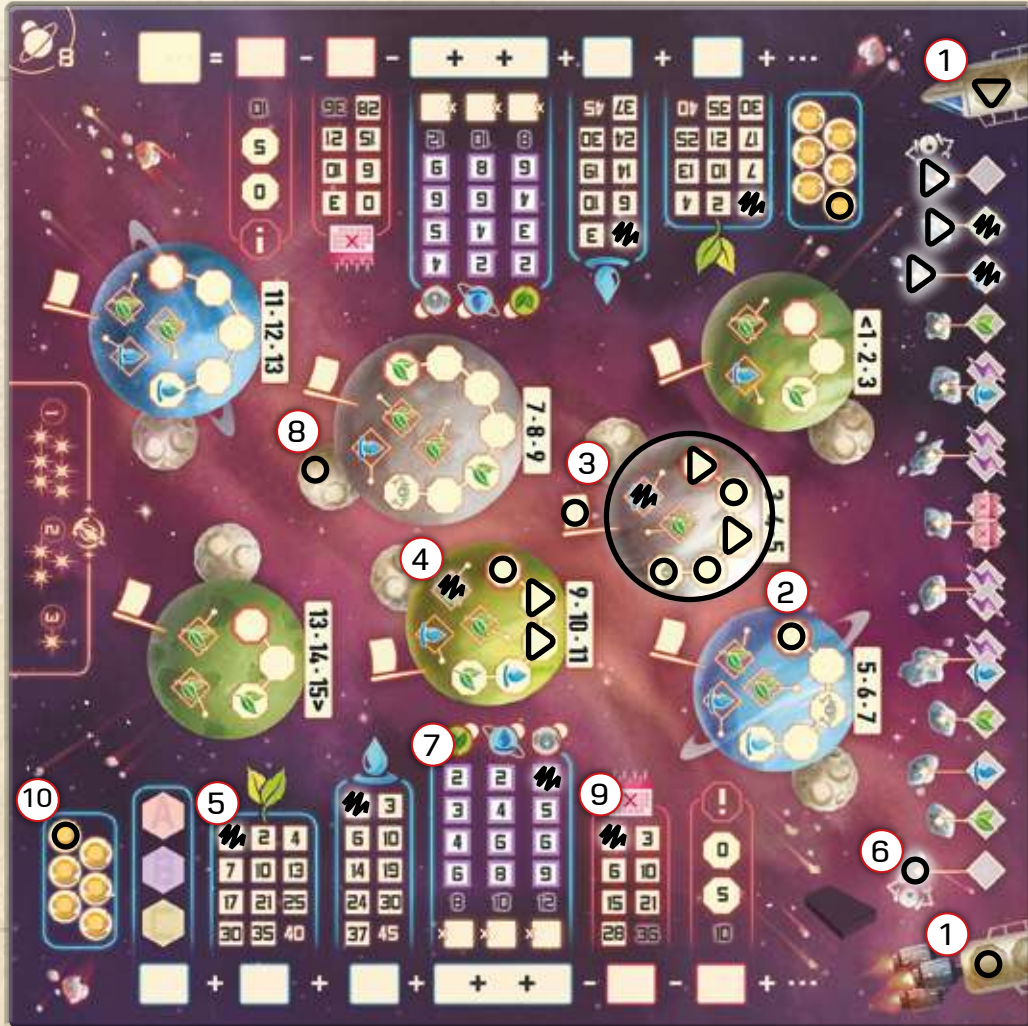



## SET UP

In this Adventure, you play on 2 sheets that you share with your 2 neighbors. Place an Adventure #8 sheet between you and the opponent on your **left**. This sheet must be oriented with the asteroids towards the center of the table. The A, B and C mission scoring boxes must be on your left side. If you are 2 players, it will be easier to set both sheets next to one another in the middle of the table.

Choose an insignia (circle, cross, triangle...) different from your 2 neighboring opponents. Write down this insignia on the starship near your scoring area on both of the sheets you share **1**.

Appoint a Captain who will place the Captain card in front of their left sheet. They will be in charge of moving the card in front of their other sheet at the end of each turn in order to clearly show which sheet to play on.

## GAME TURN

During the game, you will alternate playing on 2 sheets. On the first turn, each player plays on their left sheet. On the next turn, each player plays on their right sheet, and so on. Thus no player ever plays on the same sheet at the same time. To emphasize this, at the end of each turn, the Captain moves their Captain card in front of their new active sheet.

### 3 - WRITE DOWN A NUMBER OR RATHER DRAW AN INSIGNIA (COMPULSORY)

In this Adventure, you will not write down numbers. Use the number of the combination you picked to draw your insignia on a planet allowing this number. For example: with a number 7, you can draw your insignia in a space of the blue 5-6-7 planet or the grey 7-8-9 planet. You must draw your insignia in the first available space of the planet starting with the space with a red outline **2**.

If the space in which you draw your insignia has a Bonus symbol, you can immediately use it in addition to the action of your combination (see further: Bonus symbols).

**Control a planet:** As soon as an insignia is drawn in the last space of a planet, the control of this planet is awarded to the player who has the most insignia on this planet. You must also take into account the insignia that have been drawn on the moon of the planet, using the Planning action (see further: Planning action). Then draw on the flag the insignia of the player who controls the planet **3**. In case of a tie, the control of the planet is shared and you must draw your insignia as well as the insignia of your opponent. Circle the planet so you can better see which planets are complete.

### 4 - USE THE ACTION (OPTIONAL)



**Plant and Water action:** On the planet on which you have just drawn your insignia, cross off an available Plant symbol with the Plant action or an available Water action with the Water action **4**. Then cross off the scoring box of the lowest visible value in the corresponding scoring area **5**. If there is no available symbol corresponding to your action on the planet, then you cannot use the action.



**Robot action:** With this action, you can mine an asteroid field. For that purpose, draw your insignia on the first available asteroid. If there are one or several Bonus symbols on this asteroid, you must cross them off and immediately use them (see further: Bonus symbols). You must draw your insignia on the asteroids starting from your side of the sheet and then progressing towards your opponent **6**.



**Energy action:** You can improve the value of the planets that you control. There are 3 types of planets: green, blue, and grey ones. In your scoring area, there is a column for each of the 3 types of planets. Cross off the scoring box with the lowest visible value in the column of your choice **7**.



**Action Planning :** In addition to drawing your insignia on a planet with the number of your combination, with this action, you can draw your insignia on a moon of a planet of your choice **8**. Then you must cross off the

scoring box of the lowest visible value in your Planning scoring area (9). Note that there are only 2 available spots on each moon and that both can be occupied by the same player. You cannot draw your insignia on a moon of a planet that is already complete, and whose control has been awarded.

 **Astronaut action:** The Astronaut action allows you to modify the value of the number of the chosen combination, before you draw your insignia (-2, -1, 0, +1, +2). Moreover, circle 1 Astronaut symbol in your scoring area (10). On a next turn, in addition to the action of your combination you can use this circled astronaut symbol as a bonus to modify the value of the number of your combination. When this Astronaut symbol is used, cross it off. The use of this Astronaut symbol allows you to modify the number, but not circle a new Astronaut symbol.

**Bonus symbols:** With a **Water** or **Plant** symbol, simply cross off the lowest scoring box in your corresponding scoring area. With a **Robot** symbol, draw your insignia on an asteroid and immediately use the Bonus symbols of this asteroid. With an **Energy** symbol, cross off a scoring box to improve the value of a type of planet. With a **Planning** symbol, draw your insignia on a moon but without crossing off a scoring box in your scoring area.

## END OF THE GAME

The game ends at the end of the turn, if you have accomplished the 3 missions, or if you have crossed off the 2 System Error boxes on one of your sheets, or if all the spaces of the planets are filled in on one of your sheets.

You must tally up the scores of both sheets to get your final score. In addition to points earned for accomplished missions and penalty points lost for System Errors, tally up your points in each scoring area as follows:

- ▶ **Plants and water:** Score the points of the lowest visible scoring box.
- ▶ **Planets:** Award the control of the remaining incomplete planets. Then write down the number of planets of each

type that you control and multiply these numbers by the corresponding lowest visible value.

- ▶ **Plannings:** Subtract the lowest visible value.

## THE MISSIONS



Control 4 planets on the same sheet.



Control 1 planet of each type on the same sheet.



Using the robots, draw your insignia on 7 asteroids on the same sheet.



Improve the value twice for each type of planet on the same sheet.



Cross off 6 scoring boxes for the plants and 4 scoring boxes for the water on the same sheet.



Using the Planning actions, draw your insignia on 4 different moons on the same sheet.

## ASTRA SOLO MODE

### SET UP

Take 2 Adventure #8 sheets and place them in front of you, one next to the other. Draw the ASTRA insignia on the starships on the opposite side of both sheets (ASTRA prefers the triangle).

Each turn, ASTRA plays first on the active sheet of the turn. Then you play on the same sheet. At the end of the turn, you must move on to the other sheet. To know at any time what the current sheet is, place the Captain card in front of the left sheet. Then at the end of the turn, move it in front of the other sheet.

## GAME TURN

**ASTRA's turn:** At the beginning of each turn, instead of drawing 3 starship cards at once, start by drawing 1 starship card. ASTRA uses the number and action of this card to play its turn.

**Number:** Choose a planet corresponding to the number of the card and draw the ASTRA insignia there. If the corresponding planets are not available anymore, draw the ASTRA insignia on the next planet in ascending order. Consider that after the planet 13-14-15 comes the planet 1-2-3. When you draw the ASTRA insignia on a space with a Bonus symbol, ASTRA does not benefit from it.

Example: You draw a 11 card, but both planets 11 are not available anymore. The next planet is the planet 13-14-15 that is not available as well. Then you draw the ASTRA insignia on the planet 1-2-3.

**Control a planet:** As soon as all spaces of a planet are filled, if ASTRA has the majority, draw the ASTRA insignia on the flag. If you are tied for a planet, only draw your insignia.

**Action:** If possible, perform for ASTRA the action of the card on the same planet in which you have just drawn the ASTRA insignia:

- ▶ **Plant or Water action:** cross off a corresponding symbol still available on the planet.
- ▶ **Planning action:** draw the ASTRA insignia in a space still available on the moon.
- ▶ **Robot action:** draw the ASTRA insignia on an asteroid starting on the opposite side of the sheet. ASTRA does not benefit from the Bonus symbols of the asteroids.
- ▶ **Astronaut action:** Instead of an Astronaut action, perform a Planning action for ASTRA.
- ▶ **Energy action:** Instead of an Energy action, perform a Robot action for ASTRA.

**Your turn:** Draw 2 additional starship cards. With the first card used for ASTRA, you now have a total of 3 cards that you can use to play normally and on the same sheet. The card used for ASTRA's turn is available for you to use, since you do not have to give it to ASTRA. As usual, you simply give ASTRA the card that you did not use. This card is the only way for ASTRA to earn points at the end of the game. The actions that ASTRA plays on its turn are only there to hinder you.

**End of the turn:** Move the Captain card in front of the other sheet, which becomes the new active sheet for the next turn.

**End of the game:** It is possible that ASTRA might draw its insignia on the last available space of one of the two sheets, and therefore trigger the end of the game, before you can play. In this case, you must cross off a System Error box and still give ASTRA a card. Then, the game is over.

**SOLO BONUS:** Whenever you draw your insignia on the flags of 2 planets, circle 1 Solo bonus on the ASTRA Adventure card.

**ASTRA EFFECT:** As soon as you draw an ASTRA Effect card, either A, B or C, immediately perform 2 Planning actions for ASTRA. On the active sheet of the current turn, draw 2 ASTRA insignia on a moon. You must choose a moon whose planet is still available, and as a priority the moon of the planet with the most of your insignia (planet + moon). If several planets are tied, you can choose whichever. If the moon is already occupied by an insignia, add an ASTRA insignia next to it, then draw the 2nd insignia on the moon of the next planet in the priority order.

Example: 4 planets are available: a planet A with 4 of your insignias, a planet B with 3 of your insignias, a planet C and a planet D, each with 2 of your insignias. On the moon of planet A, there is already an insignia, then you draw an ASTRA insignia next to it. On the moon of planet B, there isn't any available space. Then, you can choose to draw the 2nd ASTRA insignia on the moon of planet C or planet D, which are tied.

# CREDITS

Game Designers: **Benoît TURPIN & Alexis ALLARD**

Artist & Graphic Designer: **Anne HEIDSIECK**

Developer: **BLUE COCKER**

English Translators: **Benoît TURPIN & Natacha CHARLON**

Rules Editor: **Dominique BODIN**

Proofreader: **Sandra GRÈS**



**BLUE  
COCKER**

**BLUE COCKER GAMES**  
Tél. : +33 5 34 28 05 01  
49 avenue de Lauragais  
31400 TOULOUSE - FRANCE  
[www.bluecocker.com](http://www.bluecocker.com)